

Cloud Intelligence

A VLDB 2012 Workshop



An Anonymization-Based Approach For Privacy-Preserving BPaaS

Mehdi Bentounsi, S. Benbernou, M.J. Atallah and C. Deme
Université Paris Descartes, France
mehdi.bentounsi@parisdescartes.fr

August 31, 2012. Istanbul, Turkey

Outline

- ✓ **Introduction and motivation**
- ✓ Overview of BPaaS by example
- ✓ Formal model
- ✓ Privacy-preserving BPaaS

Cloud computing

- Outsourcing of IT infrastructure to providers.
- Cloud services : IaaS, PaaS, and SaaS.
- Clients : SME... to take advantage of the economic model.

Cloud Federation [Papazoglou,SSAE'12]

Comprises an assembly of **IT resources** spanning various cloud providers and **diverse clouds** where each part can be independently selected by the developer and then **put together**, on demand, by the cloud provisioning system over the Internet.

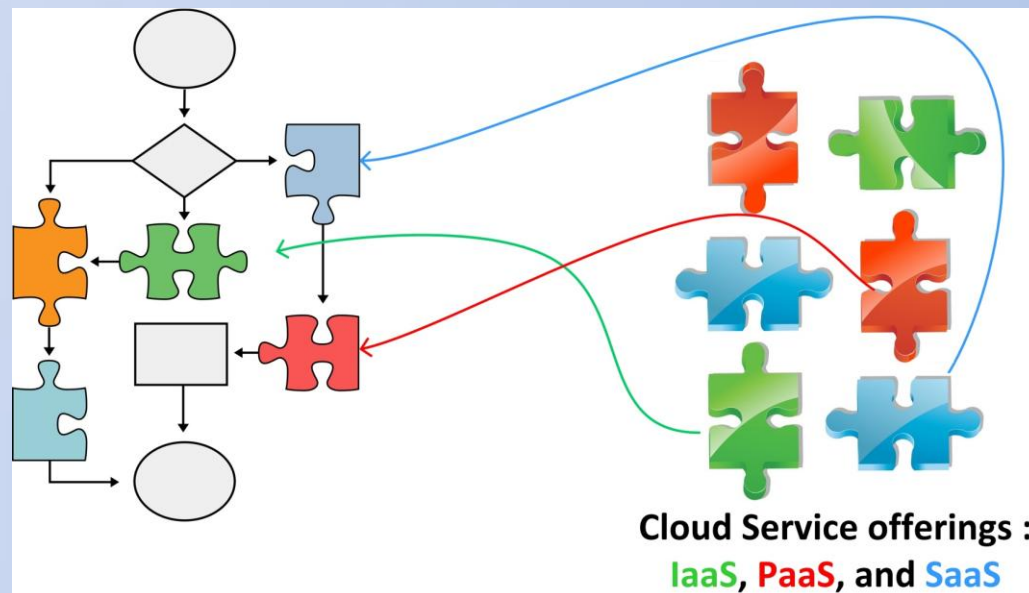

Business Process as a Service

- Why ?
 - Ease of deployment and fast provisioning.
 - Pay-per-use (reduce costs).
 - Add more capacity at peak demand (elasticity).
 - Many providers : Amazon, Google, Salesforce.com, etc.
- The next step forward in the evolution of cloud computing.
[Bittman,Gartner'11]

Motivation



- Large **multi-tenant** repositories of business process models in the Cloud.
- Duplicate fragments (clones) appear in repositories. [Uba,BPM'11]
- Reusing process fragments as **Web services** to develop new **process-based service compositions**. [Schumm,ICWE'12]

✓ **Reduce development complexity !**

Requirement



- Business processes are direct generators of revenue and key enablers of strategy.
- Innovations in business process design represent a significant proportion of costs.
- ✓ **Reusing process fragments in the Cloud must preserve the business activities of their owners !**

Outline

- ✓ Introduction and motivation
- ✓ **Overview of BPaaS by example**
- ✓ Formal model
- ✓ Privacy-preserving Business Process Outsourcing

Decomposition of processes [Khalaf,ICWS'06]

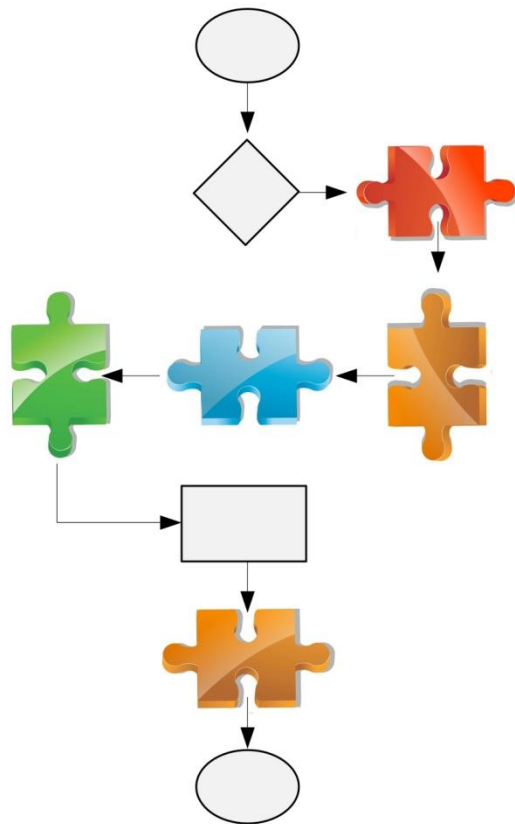

1. A business process is decomposed into a set of process fragments suitable for re-use.

Hospital Business Process

Identification of fragments [Caetano,BIS'10] and [Huang,WI'10]

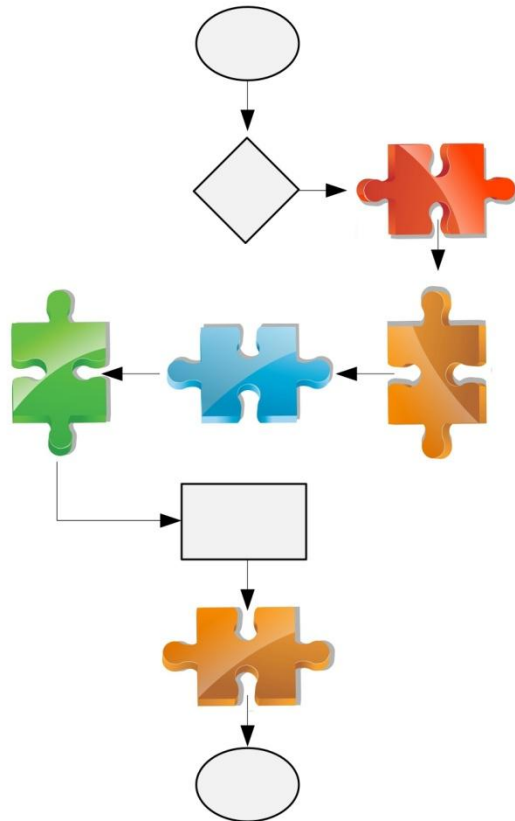

Hospital Business Process

1. A business process is decomposed into a set of process fragments suitable for re-use.

2. Each process fragment is identified and made available to be reused as a Web Service.

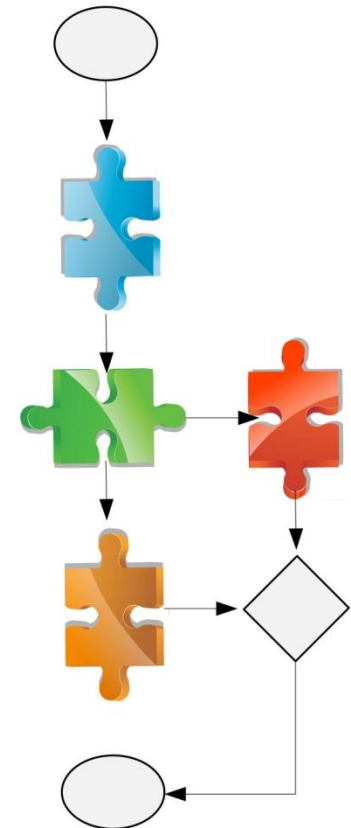

Insurance Business Process

Development of processes [Schumm, ICWE'12]

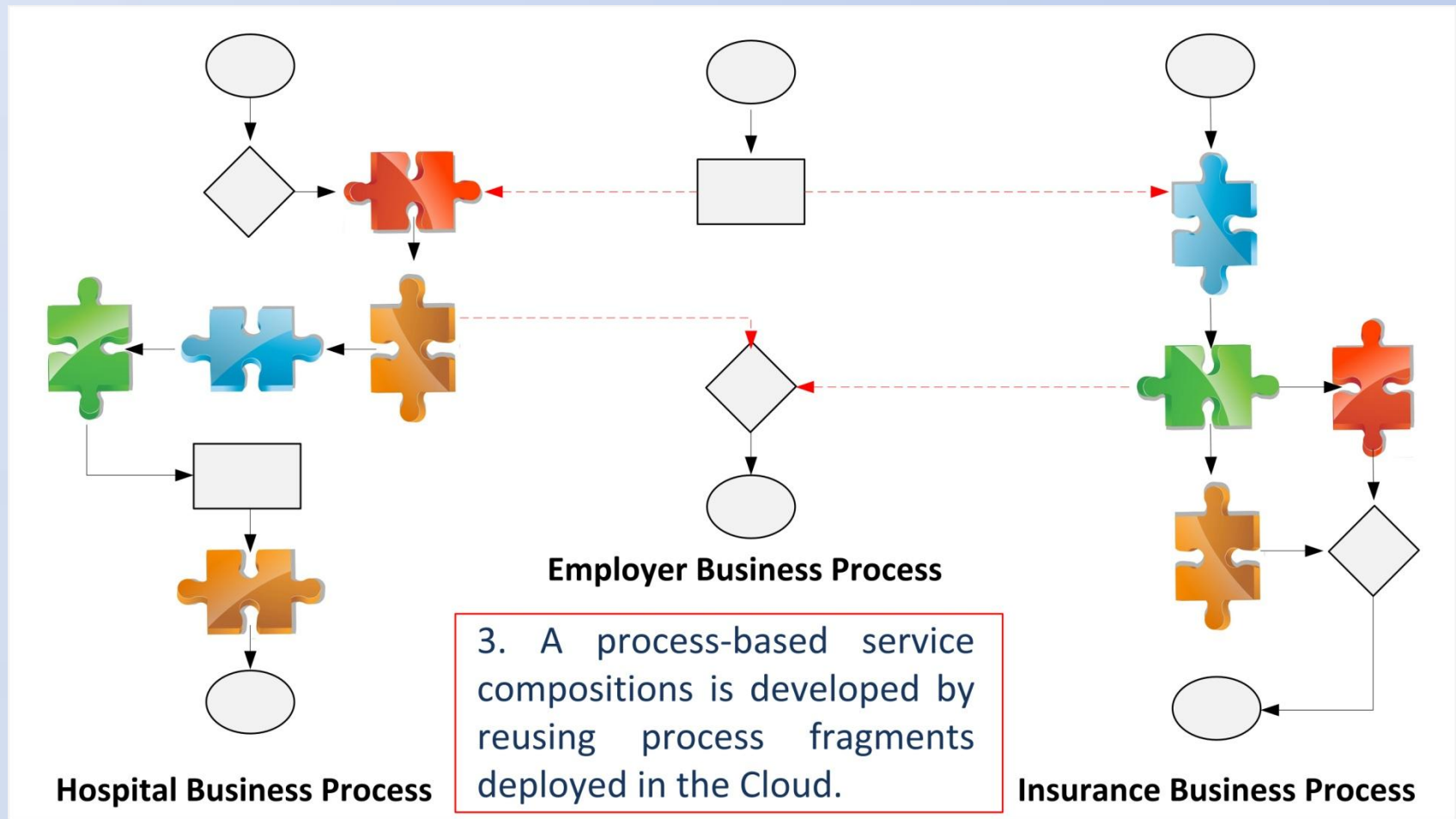

Problem



- An adversary (a curious) **can discover the provenance** of the reused process fragments.
- **Can infer connections** between end-users and organizations that outsource fragments to the Cloud.

✓ **No related work!**

Outline

- ✓ Introduction and motivation
- ✓ Overview of BPaaS by example
- ✓ **Formal model**
- ✓ Privacy-preserving BPaaS

Formal model

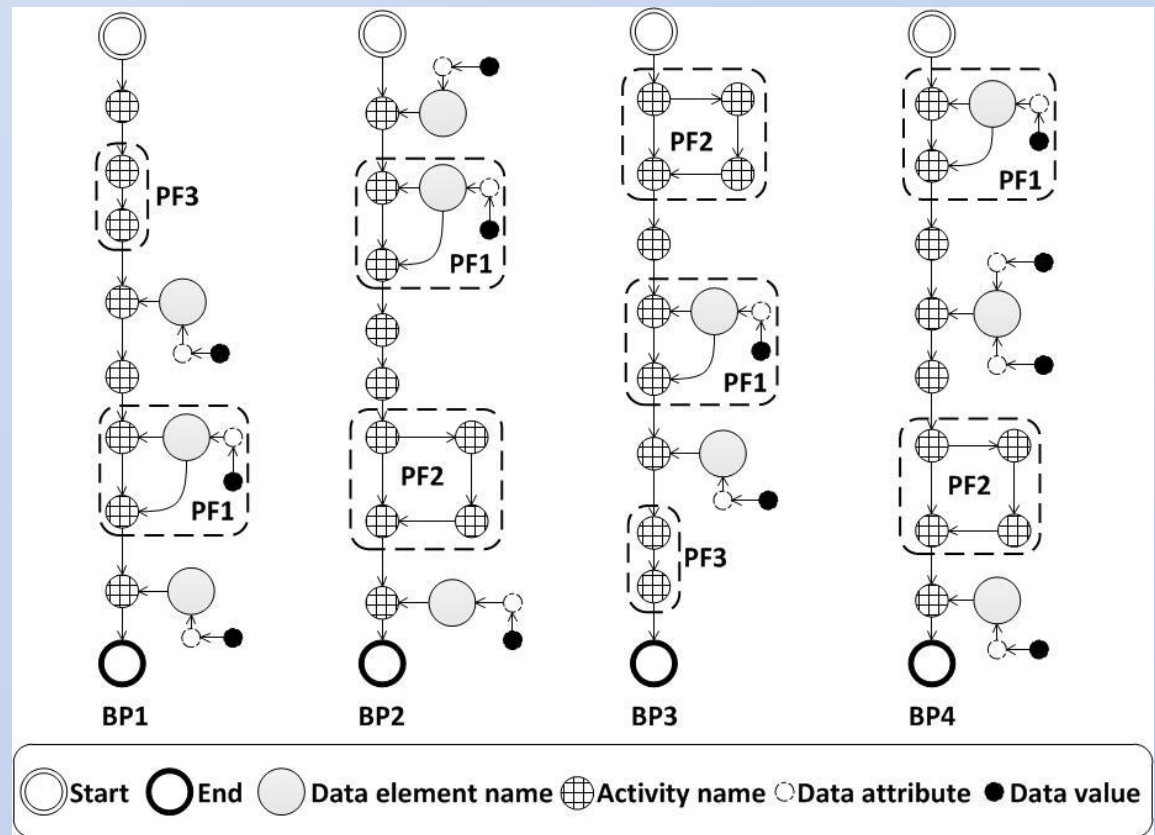

- **Business Process:** business graph. [Beerl,VLDB'06]
- ✓ **Process Fragment:** business subgraph.
- ✓ **BPaaS:** a finite set of business processes.
- ✓ **Reusing Function.**

Process Fragment Reusing

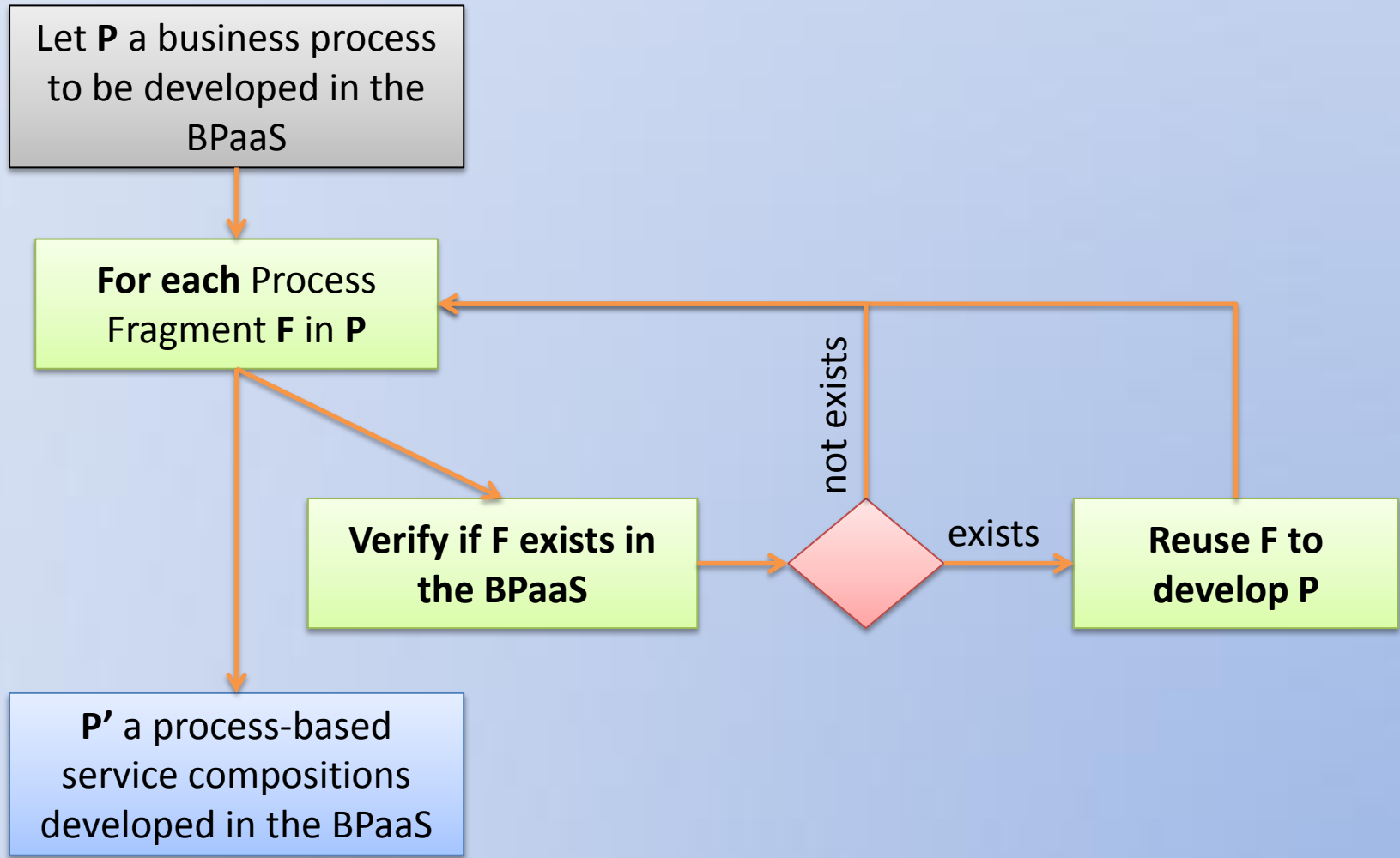

Outline

- ✓ Introduction and motivation
- ✓ Overview of BPaaS by example
- ✓ Formal model
- ✓ **Privacy-preserving BPaaS**

Privacy-Preserving BPaaS

- **First attempt** : Hide the process fragment URL and owner ID.
- **Example** : Let us consider a BPaaS with :
 - **L** organizations using it,
 - **L** process fragments implementing an activity **A**, and
 - An adversary may desire to reuse a process fragment implementing **A**.
- ✓ **A curious can make link with external informations (list of organizations using the BPaaS) and discover the provenance of the process fragment.**



Not preserve the privacy !

The Probability to discover the owner of a process fragment in the worst case is 1.

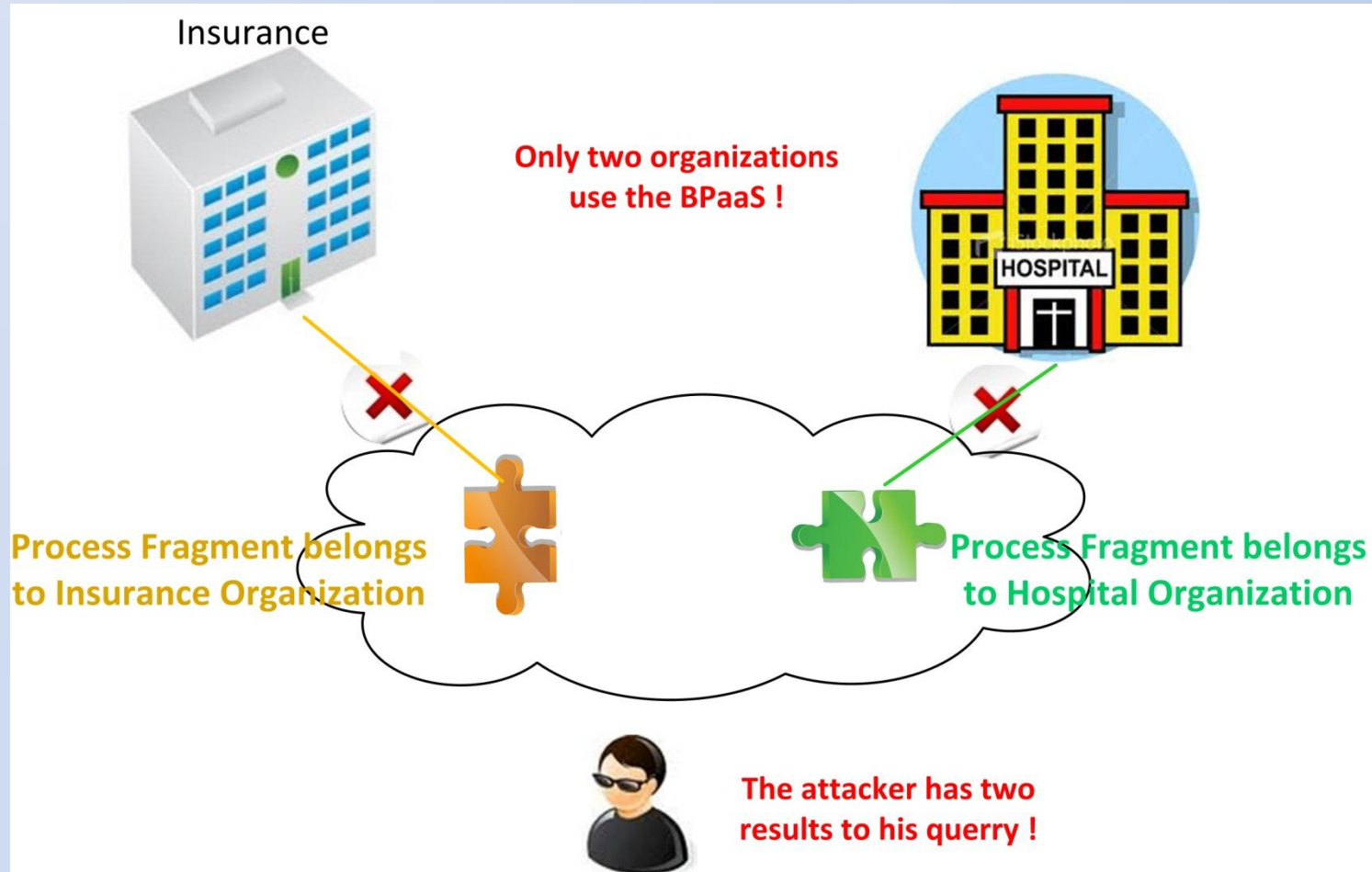

Anonymous Views



- **View on BPaaS:**
A set of process fragments having the same Activity (called clones).
- **Anonymous View on BPaaS:**
View on BPaaS having at most K clones. [Samarati, TKDE'01]
- ✓ **Make it hard for an adversary to know the provenance of a reused process fragment !**

Anonyfrag

- **Quasi-identifier fragments** : A set $A = \{A_1, A_2, \dots, A_i\}$ of Abstract Fragments (activities) in BPaaS S is called Quasi-identifier fragments or QIF, if these AFs can be used to learn the tenants business activities.
- **KI – anonyfrag requirement** : KI – anonyfrag requirement is each view V_a on BPaaS w.r.t. $a \in QIF$ must contain at most K clones.
- **KI – anonyfrag** : Given a BPaaS S used by I tenants; and an AF a with a set of at most K business subgraphs or clones in S . An adversary knows that it exists at most K clones implementing a are deployed in S ; and doesn't know :
 - Exactly the number of tenants that own the K business subgraphs among I tenants.
 - Which tenants exactly have deployed the PF in S .

Example : 2_4 - anyfrag

The Probability to discover the owner of a process fragment in the worst case is $2/4 = 0.5$!

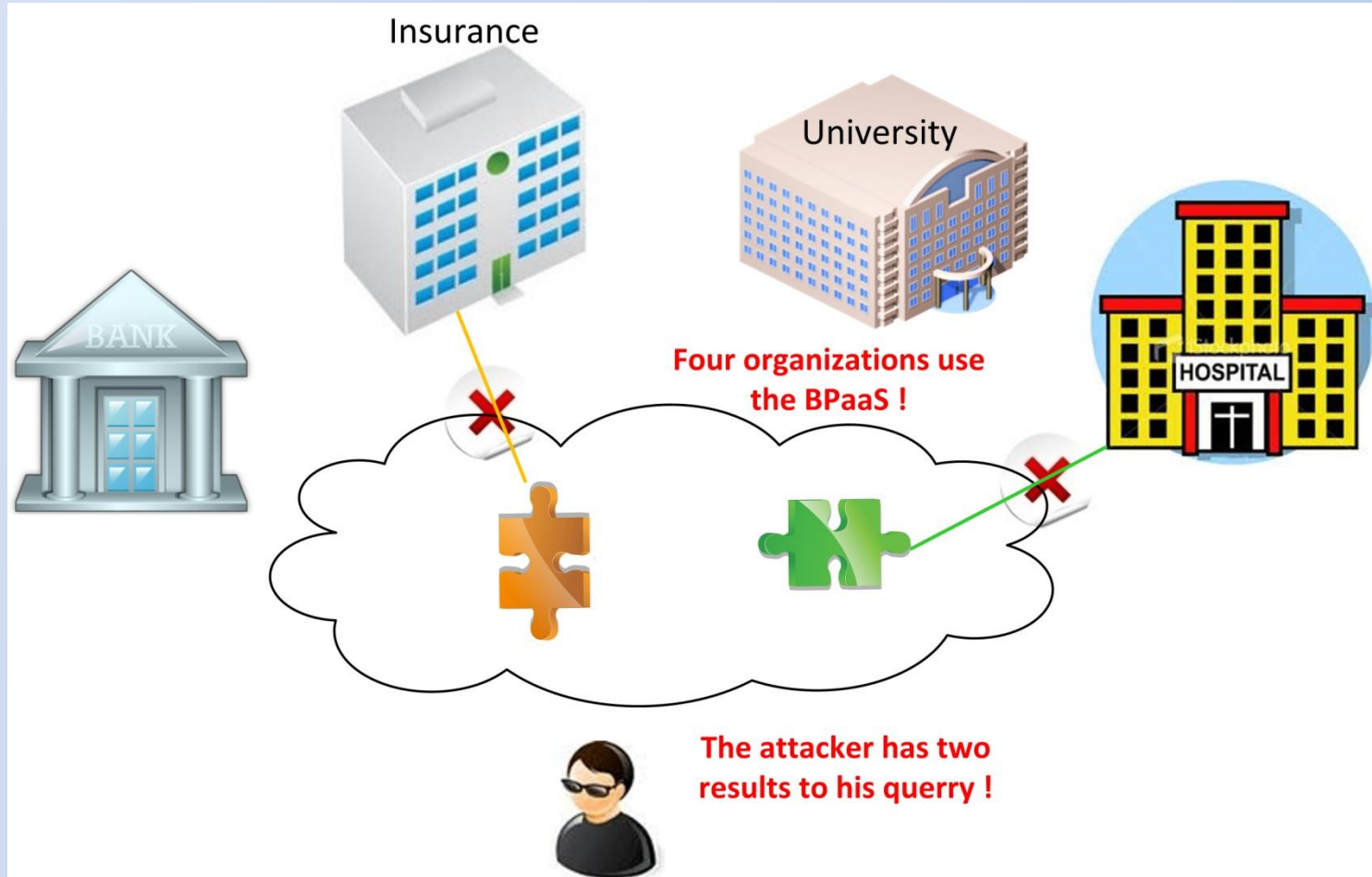

Summary

- Business process outsourcing to Business Process as a Service to take advantage of the Cloud computing model.
- Reusing process fragments to easily develop process-based service compositions and privacy risks.
- Formal model of BPaaS.
- Anonymous View on BPaaS for privacy-preserving.

Ongoing and future work

- Implementation of **Anonyfrag-platform** with real data sets. [Al-Masri,ICCCN'07] and [Al-Masri,WWW'08]
- Use **Diverse Views** to treat process fragments availability issues.
- **Monitoring** of Security and Privacy (detect attackers based on tenants' feedbacks).

Ongoing and future work

- Implementation of **Anonyfrag-platform** with real data sets. [Al-Masri,ICCCN'07] and [Al-Masri,WWW'08]
- Use **Diverse Views** to treat process fragments availability issues.
- **Monitoring** of Security and Privacy (detect attackers based on tenants' feedbacks).

Acknowledgment

- This work is supported by SOMONE and French Association Nationale de la Recherche et de la Technologie under CIFRE contract 1169/2010.
- Portions of this work were supported by Université Paris Descartes collaborative Project Brainshare.
- Portions of this work were supported by National Science Foundation Grants CNS-0915436, CNS-0913875, Science and Technology Center CCF-0939370; by an NPRP grant from the Qatar National Research Fund; by Grant FA9550-09-1-0223 from the Air Force Office of Scientific Research; and by sponsors of the Center for Education and Research in Information Assurance and Security.



References

- [Papazoglou,SSAE'12] Papazoglou, M.P.: Cloud Blueprints for Integrating and Managing Cloud Federations. In: Software Service and Application Engineering., pp.102–119. Springer (2012)
- [Bittman, Gartner 2011] Bittman, T.J.: The Road from Virtualization to Cloud Computing. In: Technical Report., Gartner (2011)
- [Uba, BPM'11] Uba, R., Dumas, M., García-Bañuelos, L., La Rosa, M.: Clone Detection in Repositories of Business Process Models. In: BPM 2011., LNCS vol.6896, pp. 248–264. Springer (2011)
- [Schumm, ICWE'12] Schumm, D., Dentsas, D., Hahn, M., Karastoyanova, D., Leymann, F., Sonntag, M.: Web Service Composition Reuse through Shared Process Fragment Libraries. In: ICWE 2012. Springer Verlag (2012)
- [Khalaf, ICWS'06] Khalaf, R., Leymann, F.: Role-based Decomposition of Business Processes using BPEL. In: ICWS 2006., pp.770–780. IEEE Computer Society (2006)
- [Caetano, BIS'10] Caetano, A., Silva, A.R., Tribolet, J.: Identification of Services through Functional Decomposition of Business Processes. In: BIS 2010., LNBI vol.47, pp.144–157. Springer (2010)
- [Huang, WI'10] Huang, Z., Huai, J., Liu, X., Zhu, J.: Business Process Decomposition Based on Service Relevance Mining. In: Web Intelligence., pp.573–580. IEEE Computer Society (2010)
- [Beeri, VLDB'06] C. Beeri, A. Eyal, S. Kamenkovich, and T. Milo. Querying business processes. VLDB, pages 343–354, 2006.
- [Samarati,TKDE'01] P. Samarati. Protecting respondents' identities in microdata release. IEEE Trans. Knowl. Data Eng.,13(6):1010–1027, 2001.
- [Al-Masri, ICCCN'07] E. Al-Masri and Q. Mahmoud. Qos-based discovery and ranking of web services. 16th International Conference on Computer Communications and Networks, pages 529–534, 2007.
- [Al-Masri WWW'08] E. Al-Masri and Q. Mahmoud. Investigating web services on the world wide web. 17th International Conference on World Wide Web, pages 795–804, 2008.

Thank you!